

Verification Method for Modelling Cooperating Processes with Coloured Sequence Diagrams

Olga Fengler

Wolfgang Fengler

Thorsten Hummel

Ilmenau Technical University

Department of Computer Architectures

email: wolfgang.fengler@tu-ilmenau.de

Outline

- 1. Motivation**
- 2. Coloured Time Interval Petri Nets and Time Verification Methods**
- 3. Colored Sequence Diagrams**
- 4. Converting Coloured Sequence Diagrams into High Level Petri Nets**
- 5. Modeling Example**
- 6. Conclusions und Outlook**

Motivation

Mechatronic Systems

- heterogeneous
- hybrid
- complex

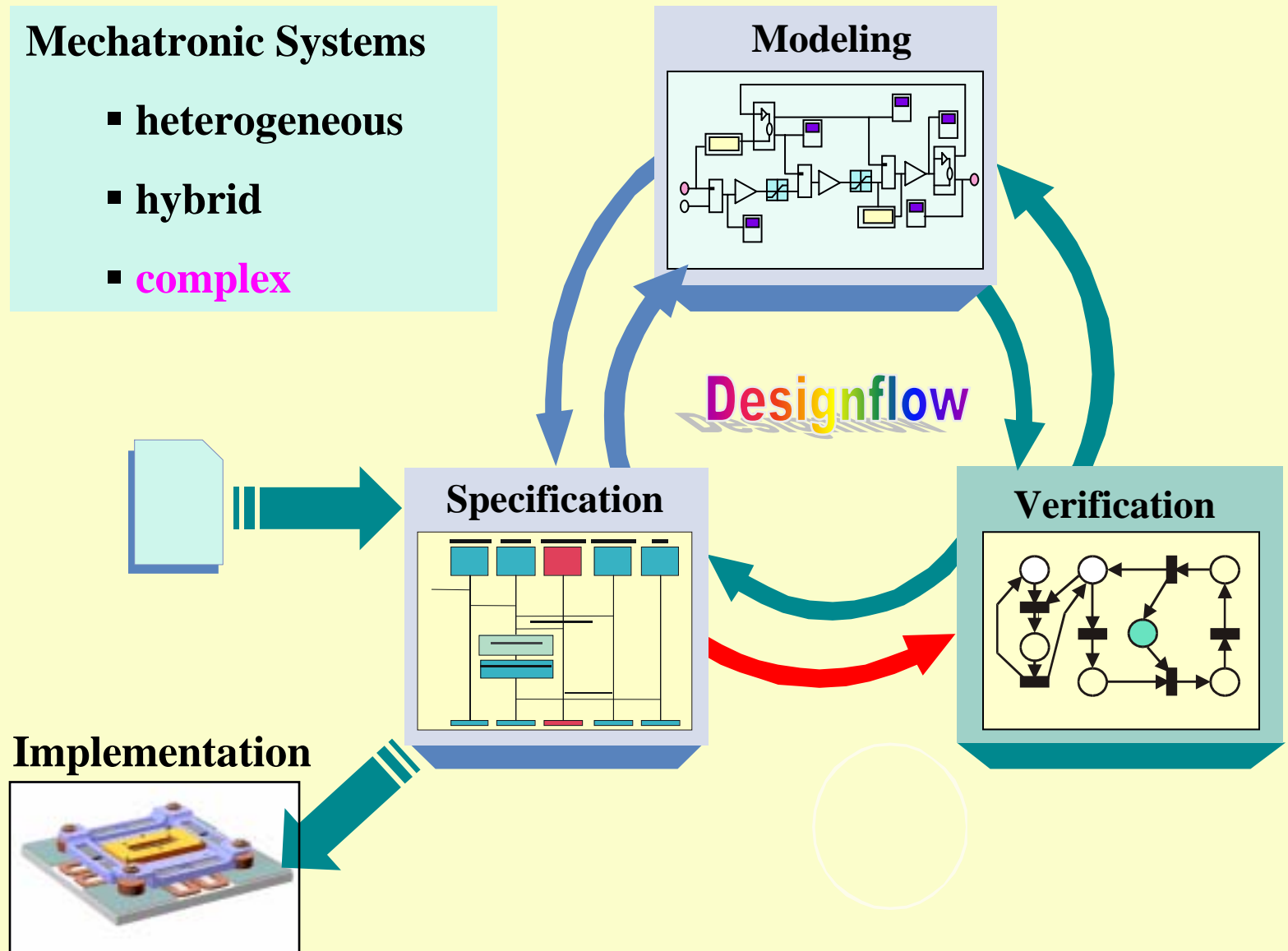

Coloured Time Interval Petri Nets

Tupel is $CTN = (P, T, F, V, K, C, mco, \zeta, I, fl)$ a Coloured Time Interval Petri Net, if:

1. $CN = (P, T, F, V, K, C, mco, \zeta)$ is a coloured Petri net,
2. I : Set of time intervals with elements $(tmin, tmax)$,
3. $fl = S \rightarrow I$ Fire-mode dependent time interval validation of transitions.

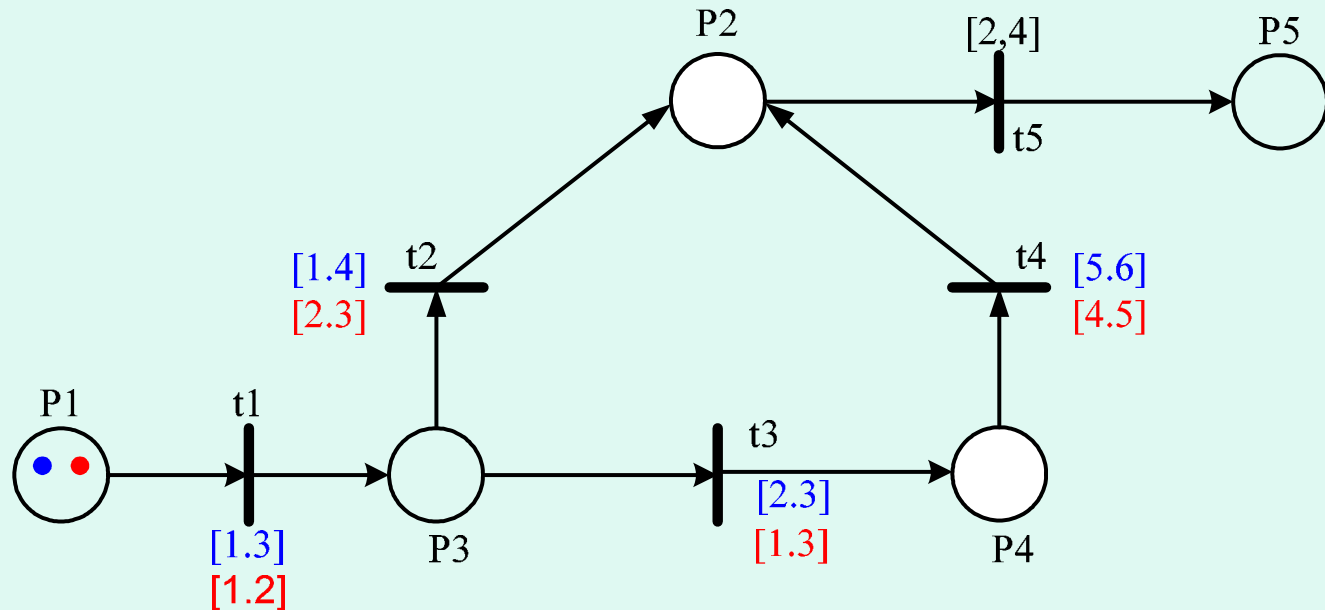

Coloured Time Interval Petri Nets

Definition des Zustandes beinhaltet auch vergangene Zeit für jede Schaltmöglichkeit

Zustand $z = (m, J)$

▪ J - Zeitfunktion

$z = ((\{1BL\}, \{1RO\}, \{1SW\}),$
 $(\{\{1RO\} \#, \{1BL\} 1\}$
 $\{\{1RO\} \#, \{1BL\} 1\})$

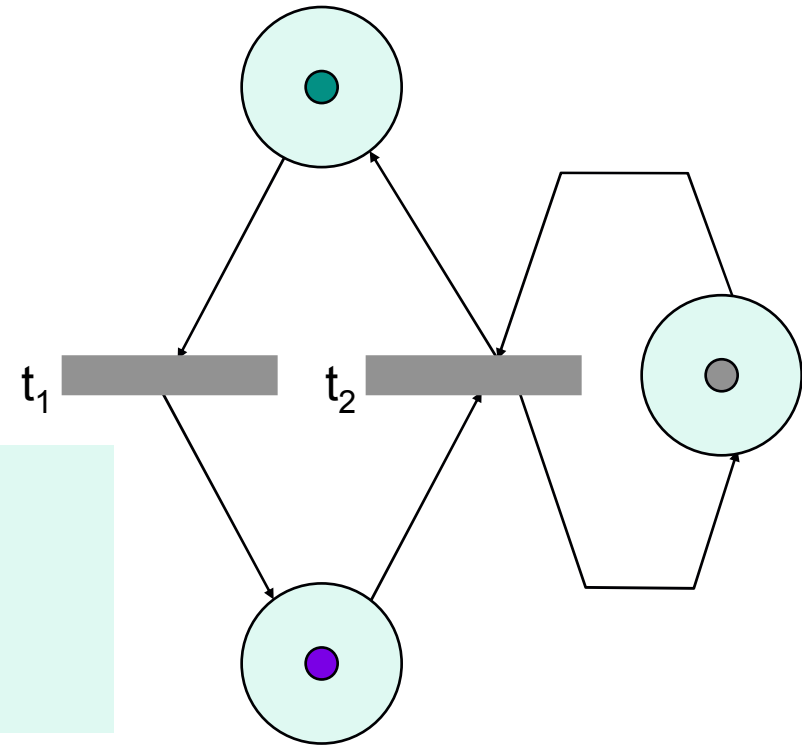

$t_1 : [3, 15], [14, 17]$ $t_2 : [0, 2], [1, 3]$

Time Verification Methods

Zustandsklassen nach Popova:

- Bestimmung der Restriktionen für jede Variable und deren Kombinationen
- Lineare Optimierung des entstandenen Ungleichungssystems
- Unter Umständen Aufteilung in mehrere Sequenzen nötig

In gefärbten Netzen:

Bildung der Zustandsklassen erfolgt wie gewohnt

Berechnung von Transitionssequenzen

- Prinzipielle Vorgehensweise analog zu ungefärbten Netzen
- Auswahl einer ganzen Transition kann zum Entstehen mehrerer Sequenzen führen

Specification → Sequence Diagrams (SD)

Sequence Diagrams are very complex and include a large number of similar or identical objects

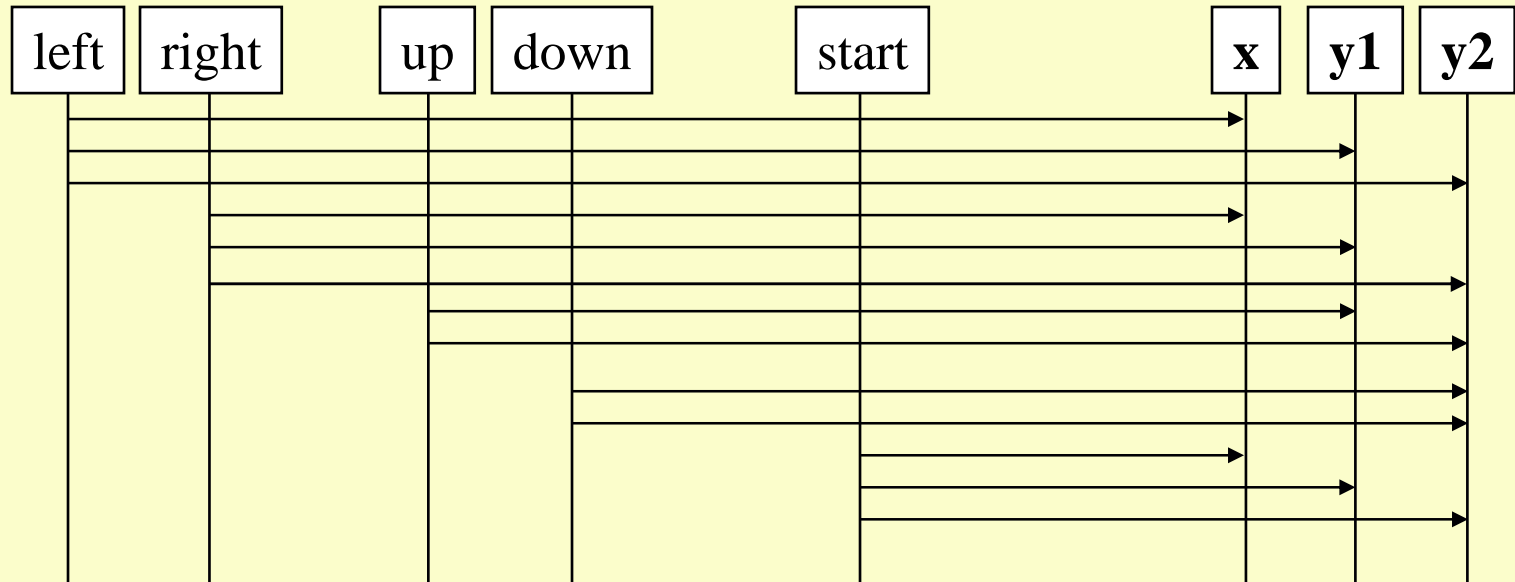

Extension of the Sequence Diagrams aims at:

- reducing the complexity of the model presentation
- achieving a compact presentation of similar processes

Folding by Coloring

A well-known concept of High Level Petri Nets

„folding“ → overlaying of instances and messages with similar content and structure

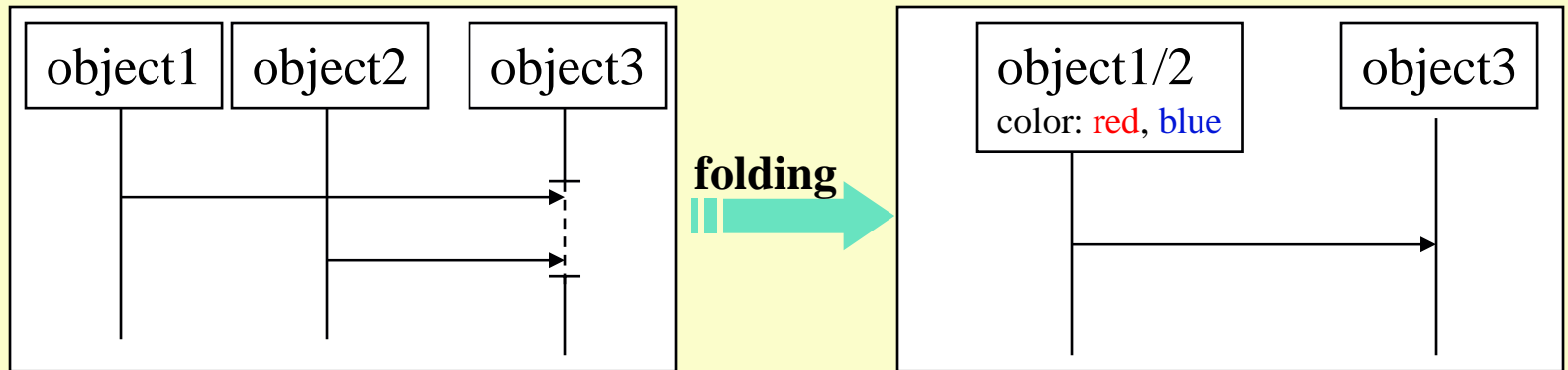

folding several objects of one diagram

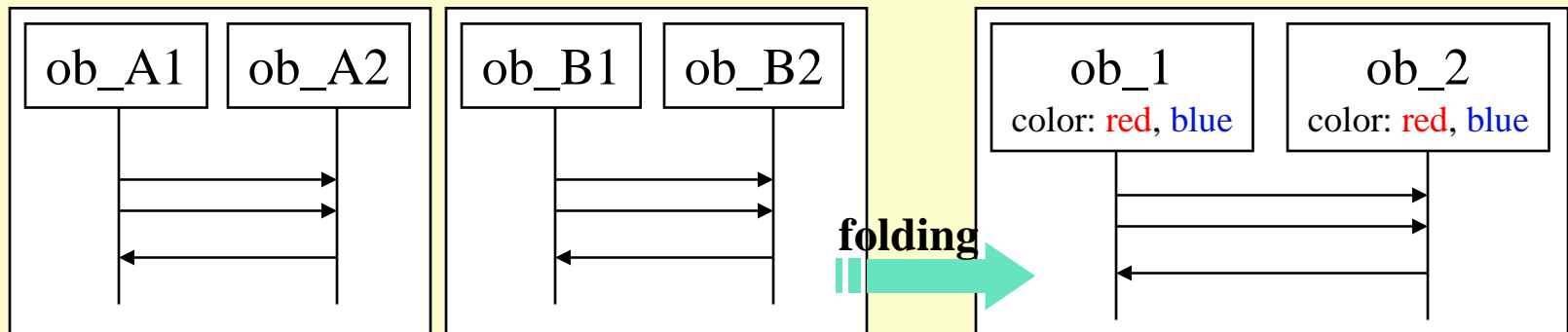

folding several objects of several diagrams

Colored Sequence Diagrams (CSD)

Colored Object (Instance)

- one graphical element → n objects
- key word „color“ identifies the objects
- colored state: the current position of a color on the life line

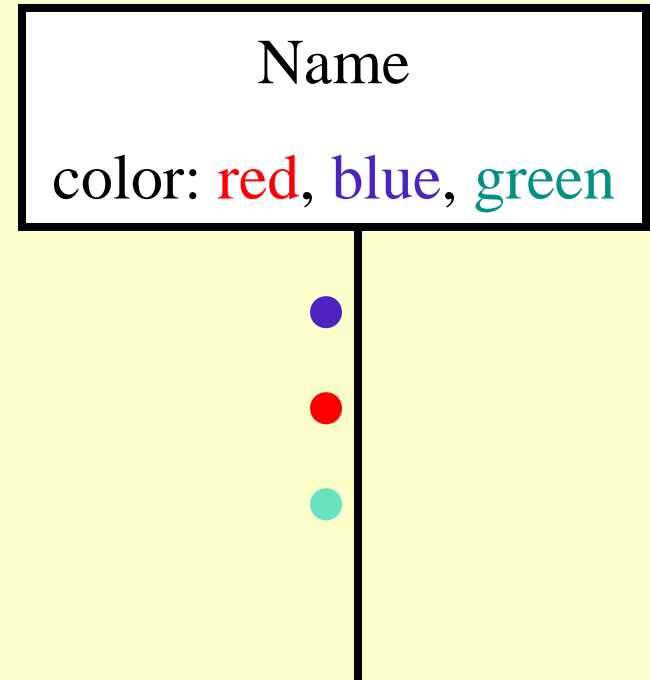

Colored Sequence Diagrams (CSD)

Colored Message: Name + Color Converting Function (CCF)

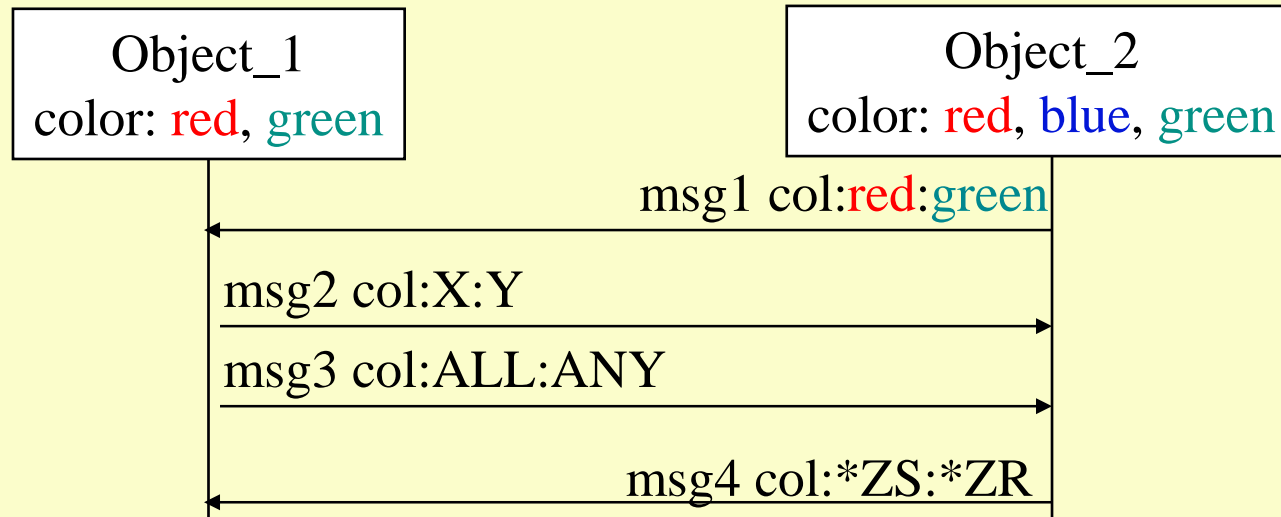

CCF → Send and Receive Arguments:

- Constant
- Variable with domain: $X = \{\text{red}, \text{green}\}$, $Y = \{\text{!blue}\}$, predefined: ALL, ANY)
- Vectors: $*Z = Z[1] \dots Z[n]$

Colored Sequence Diagrams (CSD)

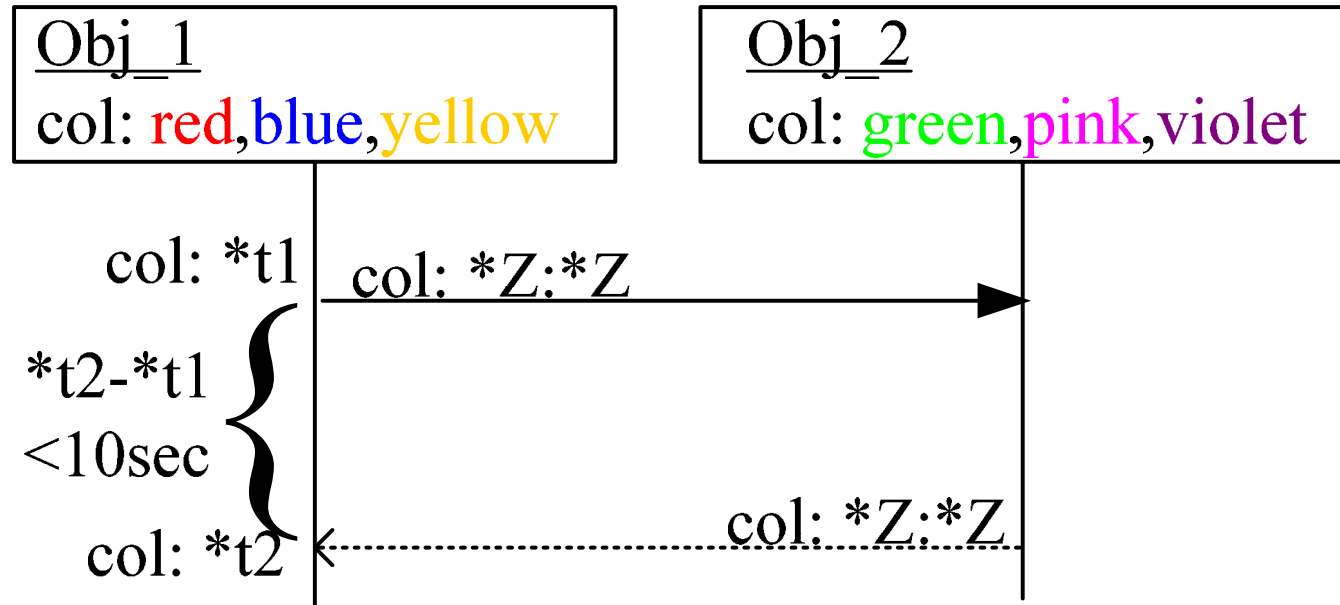

coloured time-dependent sequence diagram

Converting CSD into High Level Petri Nets

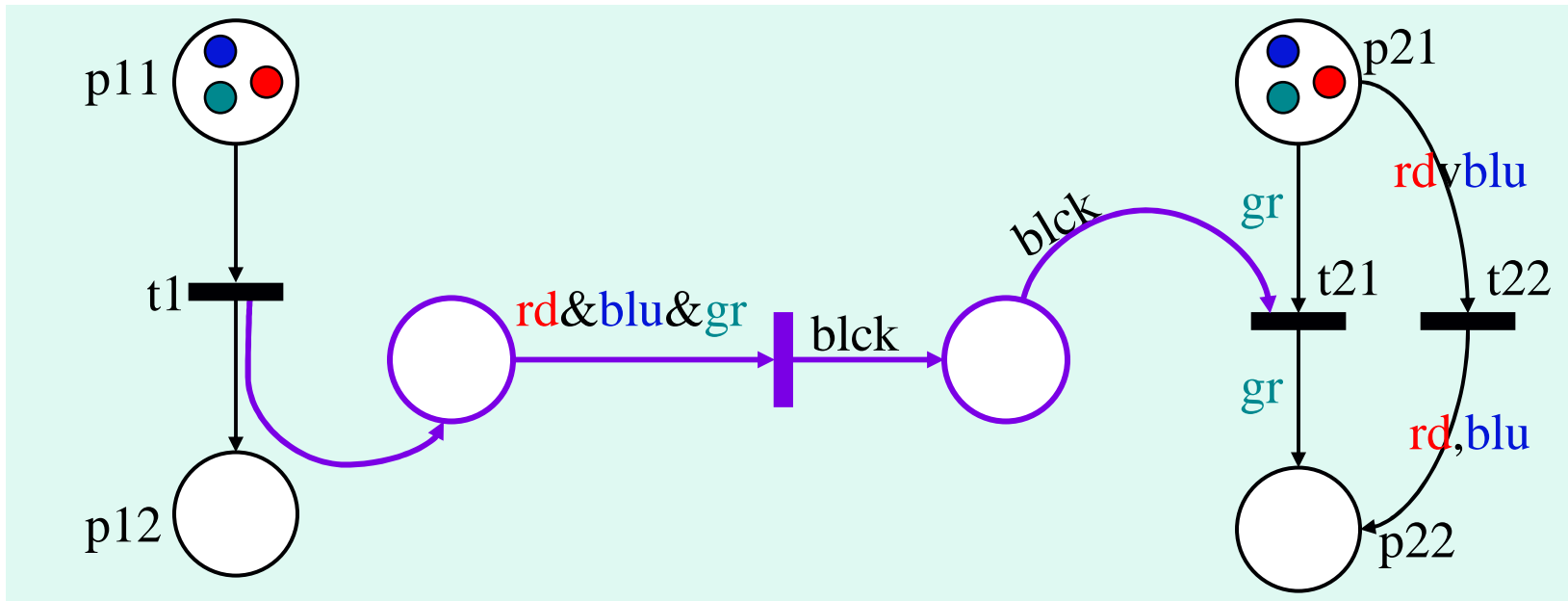

Converting CSD into High Level Petri Nets

- Splitting the coloured diagram in modules,
- Transformation from coloured diagram modules to coloured Petri net modules,
- Unification of the resulted Petri net modules to one coloured Petri net.

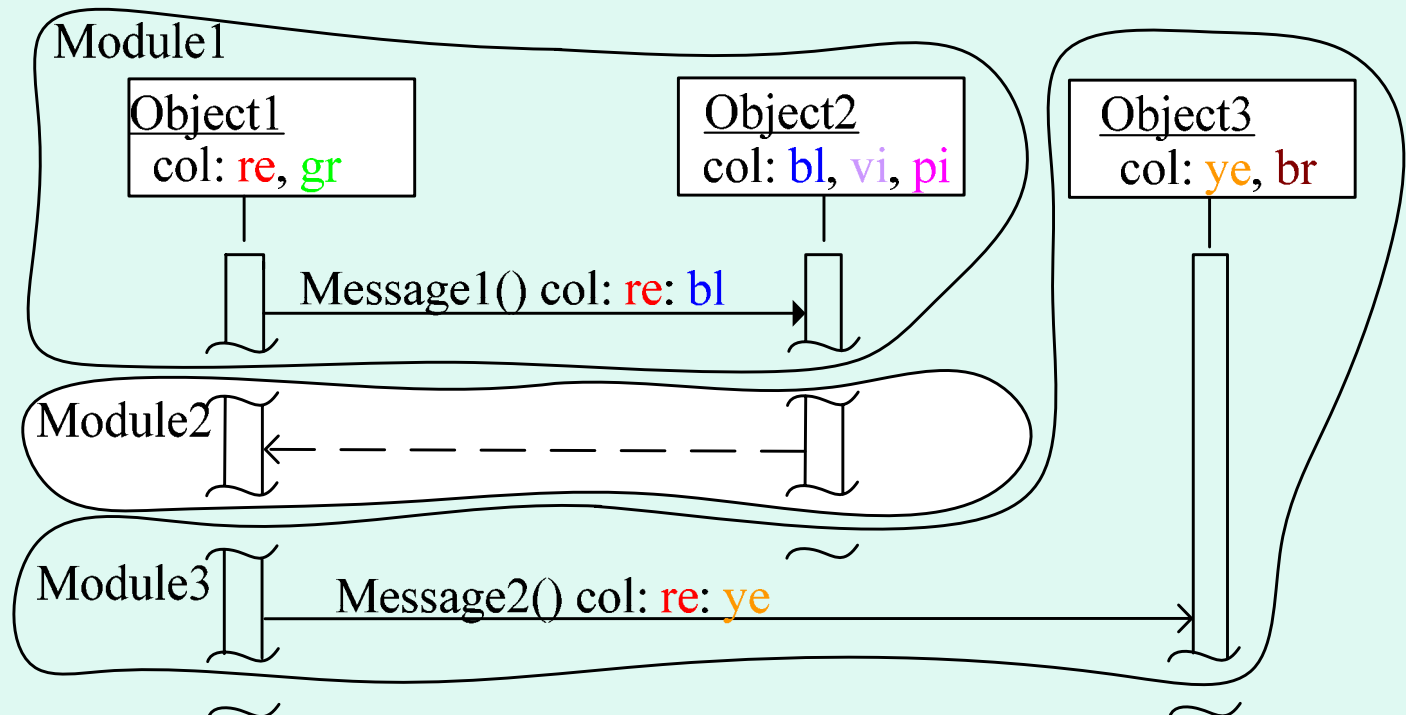

Modeling Example

Multi-Coordinate Measuring System for a Laser Cutting Table

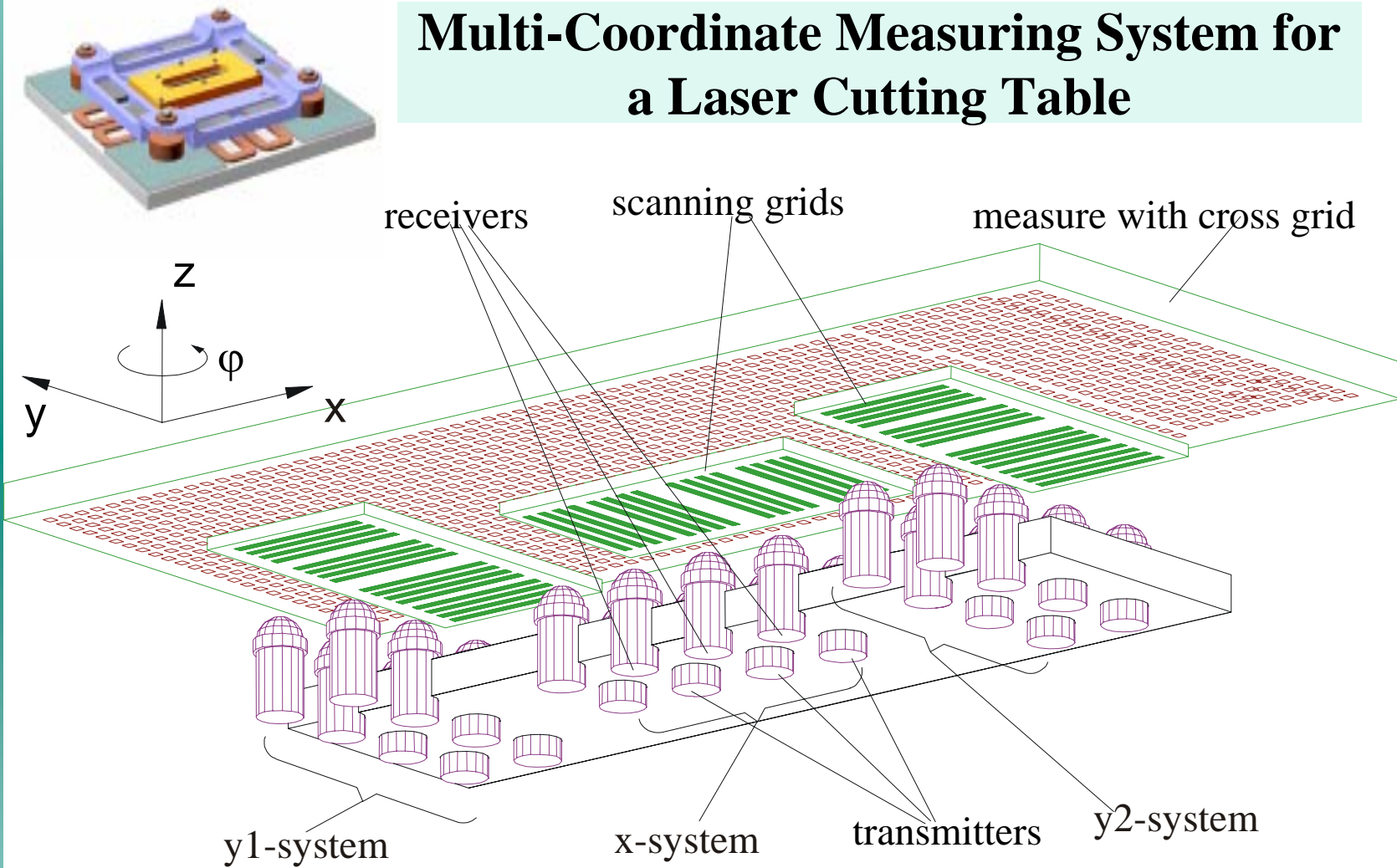

CSD of the Measuring System

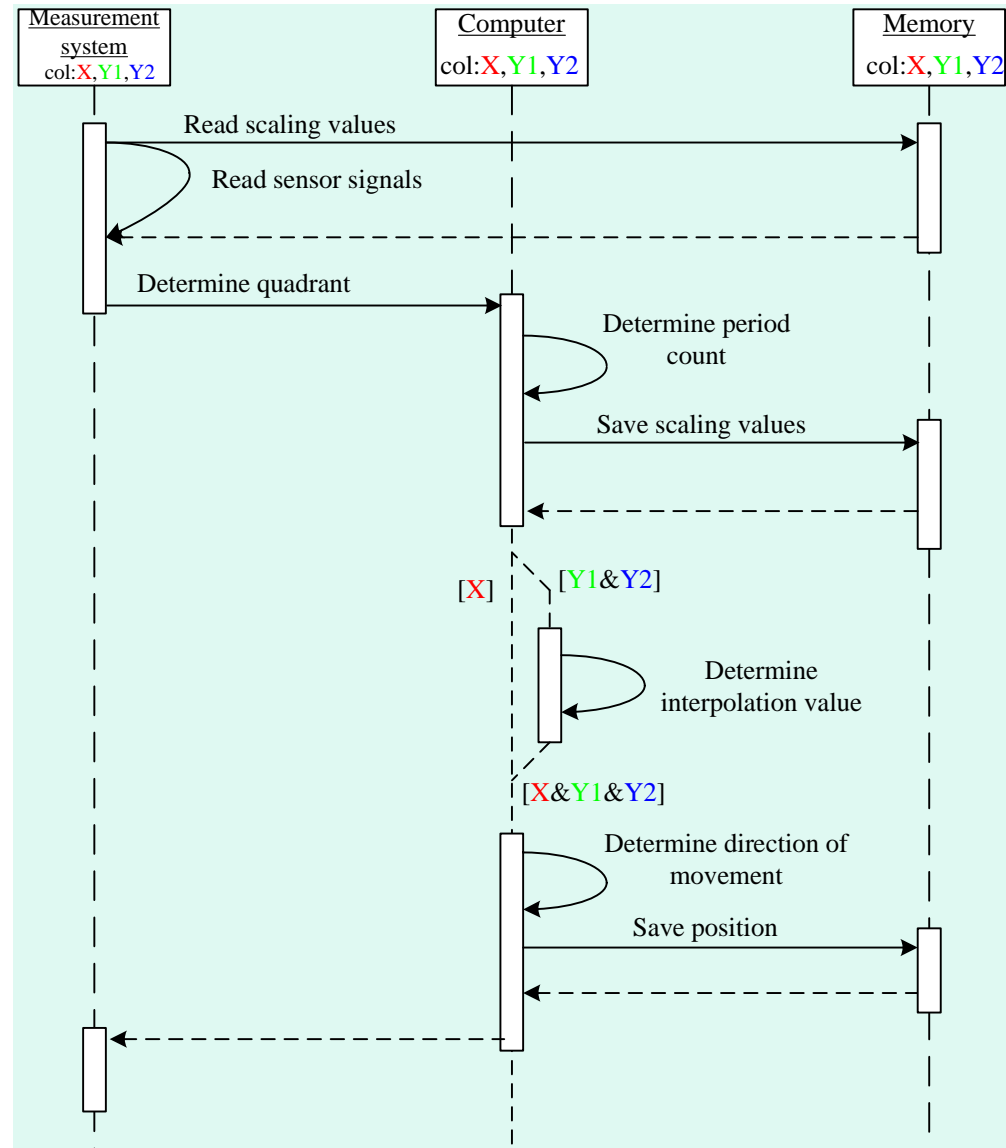

Resulting Coloured Time Interval Petri Net

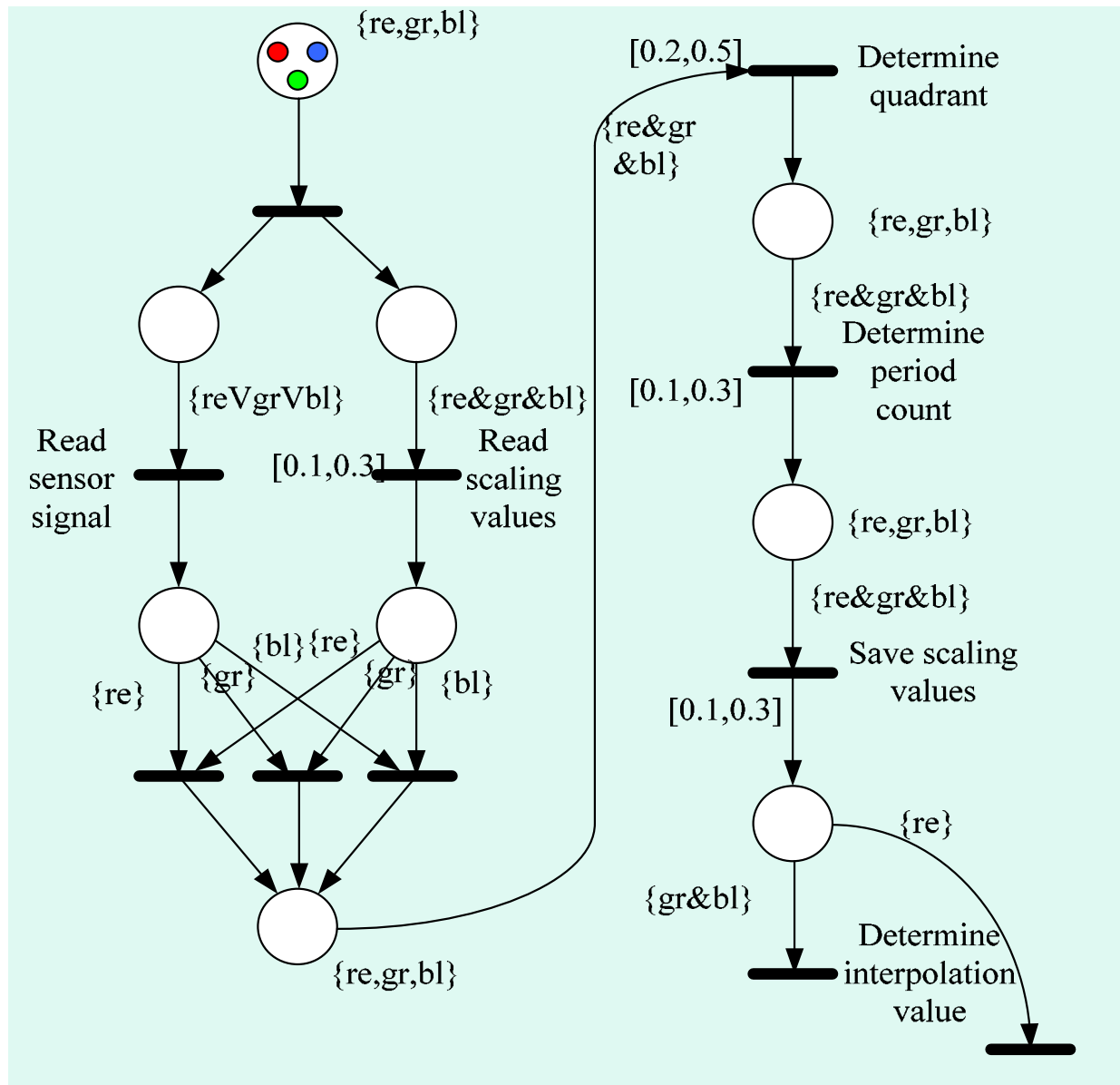

Using the described time verification method

Using the described time verification method it is possible to answer the following questions:

- Is the state reachable in a given time?
- What time can be used for certain processes to reach a defined state?
- Does the system fulfil given time restrictions?
- Under what circumstances a state is unreachable?

Conclusions und Outlook

A real world system modelled with Coloured Sequence Diagrams can be analysed with the time verification method due to the transformation of the model into Coloured Time Interval Petri Nets. Thereby the system timing behaviour and possible timing discrepancies will be checked.

Further researches will be continued with the adapting of specific analysis methods for coloured Petri nets and the transformation of CPN-notation into other state-oriented description formalisms.